

Direct-Contact Speed Switch

Rugged Housing, Electronics and Mechanical Components in One Housing

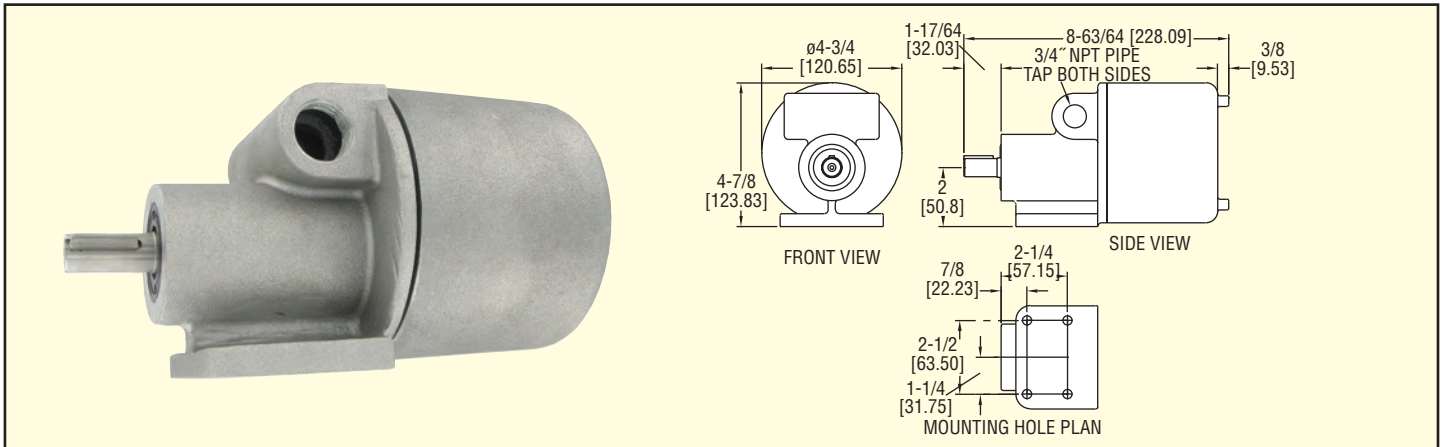

The Series DSS Direct-Contact Speed Switch is a compact switch designed to include all mechanical and electronic components in one housing. It will produce an output signal at a predetermined speed which may be either over-speed, under-speed or zero-speed. Rugged, heavy-duty construction combined with solid state electronics and photo-electric technology makes this one of the most advanced motion detectors available. Series DSS protects all valuable rotating equipment including belt conveyors, bucket elevators, rotary feeders or screw conveyors. It operates in a clockwise or counter-clockwise direction and mounts in any position.

Series DSS senses motion by means of a precision metal disc mounted on the input shaft. This disc generates measurable light pulses as a series of slots on its periphery rotate past an infra-red light source. A photo-electric sensor monitors the series of light pulses and converts them into a digital electronic signal. Solid state circuitry then analyzes the digital signal and activates or de-activates the output relay at the pre-set signal speed. It also features an adjustable built-in time delay eliminating the need for a separate start-up time delay relay.

The DSS will sense under-speed or over-speed conditions. Three signal speed ranges are available with each unit. The low signal speed range is from 0.1 to 10 RPM. The medium signal speed range is from 1 to 100 RPM, and the high speed range is 10 to 1000 RPM.

Field adjustment of the signal set point is easily accomplished by means of an adjustment screw. The signal speed ranges are selected by a three position toggle switch on the printed circuit board. For under-speed sensing, the signal point is set below the normal operating speed of the unit. The output relay will then de-energize if the speed drops below the signal set point. For over-speed sensing the signal set point is set above the normal operating speed. The output relay will energize if the speed exceeds the signal set point. The output relay can be wired either normally open or normally close.

Zero-speed sensing can be accomplished by locking the signal set point adjustment screw at its lowest setting of 0.1 RPM. The output relay will then de-energize when the shaft speed of the unit approaches zero.

SPECIFICATIONS

Temperature Limits: -50° to 150°F (-45° to 65°C).

Enclosure: Aluminum with screw cover.

Enclosure Rating: DSS-W: Meets NEMA 4X (IP66). DSS-E: Meets NEMA & 4X, UL: Class I groups C & D, Class II groups F & G.

Switch Type: DPDT.

Electrical Rating: 3 A @ 120/240 VAC, 1/10 Hp @ 120/240 VAC.

Electrical Connections: Screw terminal.

Conduit Connections: (2) 3/4" female NPT.

Mounting Orientation: Any.

Set Point Adjustment: Adjustment screw.

Power Requirements: 105-135 VAC, 50/60 Hz, 210-250 VAC, 50/60 Hz; or 24 VAC/DC depending on model.

Power Consumption: 3 W.

Repeatability: 2% max at constant voltage and temperature.

Pick-up Point: 3 speed ranges at which relay will energize:

Low: 0.1 to 10 RPM.

Medium: 1 to 100 RPM.

High: 10 to 1000 RPM.

Signal Point: Speed at which relay will de-energize. Recommended to be 15 to 20% lower than pick-up point.

Start-up Delay: Adjustable up to 45 s.

Radial Load on Input Shaft: 125 lb max.

End Thrust on Input Shaft: 100 lb max.

Rotation: Either clockwise or counter-clockwise.

Driving Torque: 1"/lb max.

Shaft: 5/8" diameter with 3/16" x 7/8" key.

Weight: 5 lbs (2.3 kg).

Agency Approvals: cUL, UL.

Model	Supply Voltage	Enclosure Rating	Enclosure Type
DSS-W1	120 VAC	Weatherproof	Aluminum
DSS-E1	120 VAC	Explosion-Proof	Aluminum
DSS-W2	240 VAC	Weatherproof	Aluminum
DSS-E2	240 VAC	Explosion-Proof	Aluminum
DSS-W3	24 VAC/DC	Weatherproof	Aluminum
DSS-E3	24 VAC/DC	Explosion-Proof	Aluminum

ACCESSORIES

Model	Description
A-426	Stub Shaft
A-427	Flexible Coupling
A-428	Coupling Guard
A-422	Mounting Bracket for DSS Switch